

E1

AR E1-MAXI.A

ELCA
RADIOCONTROLS

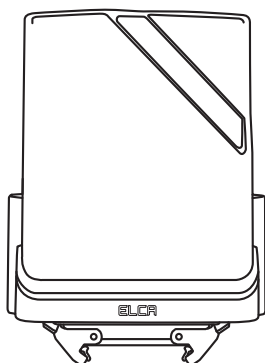

USER MANUAL

PART 2: RECEIVING UNIT

Instructions translated from the original

This manual, including all its parts, and all the instructions contained in it must be read carefully and understood before each installation, use, maintenance or reparation of the ELCA radio remote control.

OTHER LANGUAGES

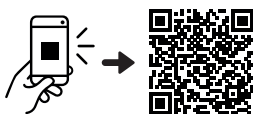

<https://qrcode.elcaradio.biz/man/24a8bca04a09a6b017188854dd5e32e4>

WARNING



THIS PART OF THE MANUAL CONSISTS OF: Part 2 – Information, instructions and general warnings for the Receiving Unit. The manual consists of Part 1 "Transmitting Unit user manual", Part 2 "Receiving Unit user manual", Position of the controls and the Connection diagram.

THIS MANUAL, INCLUDING ALL ITS PARTS, AND ALL THE INSTRUCTIONS CONTAINED IN IT MUST BE READ CAREFULLY AND UNDERSTOOD BEFORE EACH INSTALLATION, USE, MAINTENANCE OR REPARATION OF THE ELCA RADIO REMOTE CONTROL.

FAILURE TO READ THE MANUAL AND COMPLY WITH ALL THE APPLICABLE WARNINGS AND INSTRUCTIONS, OR ANY RESTRICTION PROVIDED IN THIS MANUAL CAN CAUSE SERIOUS PHYSICAL INJURIES OR DEATH AND/OR DAMAGE TO PROPERTY.

THE ELCA RADIO REMOTE CONTROL IS NOT AN INDEPENDENT PRODUCT AND IS EXCLUSIVELY A COMPONENT OF A MACHINE THAT:

- PERMITS A RADIO REMOTE CONTROL TO BE USED IN AN APPROPRIATE MANNER,
- CAN BE OPERATED SAFELY AND IN COMPLIANCE WITH ALL LEGAL PROVISIONS, REGULATIONS AND STANDARDS APPLICABLE TO THIS RADIO REMOTE CONTROL.

ACCORDINGLY, IT IS THE RESPONSIBILITY OF THE MANUFACTURER AND THE DESIGNERS OF THE MACHINE ON WHICH YOU INTEND TO INSTALL THE ELCA RADIO REMOTE CONTROL to carry out a careful and in-depth risk assessment to determine whether the Elca radio remote control is suitable for the safe and efficient use of the Machine, taking into account the conditions of use and the intended uses, and that the installation, maintenance and use of the Elca radio remote control and all its components are carried out only and entirely in accordance with this Manual and in compliance with all local safety rules, standards and regulations (referred to herein as "Laws, Regulations and Standards").

With reference to the US market, the Laws, regulations and Standards include all regulations and standards of the Occupational Safety & Health Administration (OSHA) (<http://www.osha.gov>), all federal, state and local laws and provisions, the construction and electric devices codes and all applicable standards, including, but not only, ANSI standards.

It is the responsibility of the Manufacturer and the designers of the Machine on which you intends to install and use the Elca Radio Remote Control to make sure that the structure, condition, organisation and the markings of the Machine as well as how it is installed in its place of use are appropriate and allow the Machine to be used and controlled safely and reliably using the interface of the Elca Radio Remote Control.

IT IS THE RESPONSIBILITY OF THE USER OF THE SYSTEM AND THEIR DESIGNERS that the installation, maintenance and use of the Elca Radio Remote Control and all its components are carried out only and entirely in accordance with this Manual and in compliance with all applicable Laws, Regulations and Standards, also local. It is also the responsibility of the Owner, the system user and their designers to make sure that the structure, the condition, the organisation and the markings of the Machine and the place where the Elca Radio Remote Control is installed and used are appropriate and allow the Machine to be used and controlled safely and reliably using the interface of the Elca Radio Remote Control.

ONLY QUALIFIED AND SUITABLY TRAINED PERSONNEL ARE ALLOWED TO CONTROL AND USE THE ELCA RADIO REMOTE CONTROL AND THE MACHINE CONTROLLED BY THE ELCA RADIO REMOTE CONTROL.



ONLY QUALIFIED AND SUITABLY TRAINED PERSONNEL ARE ALLOWED ACCESS TO THE VICINITY OF THE MACHINE CONTROLLED BY THE ELCA RADIO REMOTE CONTROL.

INADEQUATE INSTALLATION, OPERATION, MAINTENANCE AND ASSISTANCE OPERATIONS ON THE ELCA RADIO REMOTE CONTROL CAN CAUSE SERIOUS PHYSICAL DAMAGE OR DEATH AND/OR DAMAGE TO PROPERTY. For further assistance refer to this Manual and all its parts, or else contact Elca. Elca is not responsible for and accepts no liability for any installation of the Elca Radio Remote Control carried out by Elca itself, or for any use or maintenance of the Elca Radio Remote Control that do not fully comply with all the instructions and warnings supplied by Elca and with all applicable Laws, Regulations and Standards, also local.

Elca is not responsible for and accepts no liability for any alterations or modifications of the Elca Radio Remote Control, or for the use of non-original Elca parts that are used together or incorporated inside the Radio Remote Control itself.

IT IS THE RESPONSIBILITY OF THE OWNER, AND USER OF THE SYSTEM AND ITS DESIGNERS to make sure that the Elca Radio Remote Control is always maintained and serviced in compliance with all the instructions and warnings provided by Elca, and in compliance with all applicable Laws, Regulations and Standards, also local.

IT IS THE RESPONSIBILITY OF THE OWNER, THE USER OF THE SYSTEM AND THEIR EMPLOYEES MANAGERS AND SUPERVISORS to make sure that all the Users of the Elca Radio Remote Control and all those that work or will work with or near the Machine operated by or through the Elca Radio Remote Control are completely and adequately instructed and trained by qualified persons on the correct and safe use of the Elca Radio Remote Control and the Machine, including without restrictions the complete familiarity with and understanding of the warnings and instructions provided by Elca, and all applicable Laws, Regulations and Standards, also local; it is equally also their responsibility to make sure that these Users or other Persons use or work always in a safe manner with the Elca Radio Remote Control and e ONLY in compliance with the instructions and warnings provided by Elca and in compliance with all applicable Laws, Regulations and Standards, also local. FAILURE TO COMPLY WITH THIS INSTRUCTION CAN CAUSE SERIOUS PHYSICAL INJURIES OR DEATH AND/OR DAMAGE TO PROPERTY.

IT IS THE RESPONSIBILITY OF THE OWNER, THE USER OF THE SYSTEM AND THEIR EMPLOYEES MANAGERS AND SUPERVISORS to make sure that the area where the Machine is located and is operated by the Elca Radio Remote Control is clearly marked and indicated, in compliance with all the instructions and warnings provided by Elca, and in compliance with all applicable Laws, Regulations and Standards, also local, and that there are sufficient indications that notify EVERYONE that the machine is operated by or through a Radio Remote Control, and that prohibit any unauthorised access to the area. FAILURE TO COMPLY WITH THIS INSTRUCTION CAN CAUSE SERIOUS PHYSICAL INJURIES OR DEATH AND/OR DAMAGE TO PROPERTY.

IF THE ELCA RADIO REMOTE CONTROL IS NOT USED SAFELY AND IN ADHERENCE TO THE INSTRUCTIONS AND WARNING PROVIDED BY ELCA, AND IN CONFORMITY WITH APPLICABLE LAWS, REGULATIONS AND STANDARDS, ALSO LOCAL, AND/OR IF USE OF THE RADIO REMOTE CONTROL IS PERMITTED TO USERS OR OTHER PERSONS THAT ARE NOT ADEQUATELY TRAINED TO USE THE SYSTEM OR THE MACHINE ON WHICH IT IS INSTALLED SAFELY AND CORRECTLY, CAN CAUSE SERIOUS INJURIES OR DEATH AND/OR DAMAGE TO PROPERTY.

INDEX

1 Use and Maintenance Manual	5
1.1 Structure.....	5
1.2 Definitions.....	5
1.3 Symbols	5
1.4 Who these instructions are for	5
1.5 Storage of the instructions	5
1.6 Updating the Manual.....	6
1.7 Intellectual property.....	6
2 Series, Radio Remote Control and Unit	6
3 Conformity	6
3.1 EU conformity	6
3.2 Countries of use.....	6
4 Manufacturer's identification	6
5 Assistance and spare parts	6
6 Warranty	6
7 Safety warnings	6
7.1 General information.....	6
7.2 Risk analysis for remote-controlled Machines	7
7.3 Delay in the command response time.....	8
7.4 Unintended activations of the commands	8
8 Radio Remote Control of the Range	8
8.1 Characteristics	8
8.2 Frequencies and radio link	8
8.3 Technical data of the range	9
8.4 Identification of the Radio Remote Control	9
8.5 Transportation and/or storage.....	9
8.6 Applications.....	10
8.7 Training of the personnel: Installation and maintenance	10
8.8 Classification of the controls.....	10
9 Warnings for the installation	10
9.1 Warnings for the Installer	11
9.2 Positions and mounting of the Receiving Unit	11
9.3 Receiving Unit wiring	11
9.4 Positioning the antenna.....	11
10 Instructions for the User	12
10.1 Use of the Radio Remote Control and operating conditions	12
10.2 General warnings for the User	12
10.3 Environmental conditions of use	12
10.4 Warnings before starting work	12
10.5 Warnings during normal use	13
10.6 Warnings for after its use	13
11 Description of the Receiving Unit	13
11.1 Technical data	13
11.2 The Position of the controls and Connection diagram	14
11.3 Receiving unit data plate	14
11.4 Indicator lights	14
11.5 Extension card	14
12 General operating instructions	15
12.1 Mother Board	15
12.2 Radio receiving module	15
12.3 Board with identification code.....	15
12.4 DIP switch	15
12.5 Command outputs	15
13 Installation	15
13.1 Receiver unit fastening	15
13.2 Wiring indications	15
13.3 Testing	16
14 Maintenance	16
14.1 Maintenance of the Radio Remote Control - general instructions	16
14.2 Routine maintenance	16
14.3 Special maintenance.....	17
15 Guide to solving problems	17
15.1 Solutions in the event of malfunctions.....	17
16 Decommissioning and disposal	17
16.1 Decommissioning	17
16.2 Disposal	17

1 Use and Maintenance Manual

1.1 Structure

The Instruction Manual for use and maintenance consists of two parts: together they constitute the Elca Radio Remote Control of the series E1.

The Manual should be read, understood and applied by the Owner of the Radio Remote Control, by the User and by all those who, for whatever reason, operate the Radio Remote Control or the Machine on which it is installed.

This Part (Called Part 2) deals with the Receiving Unit. Part 1 (to which you are referred) deals with the Transmitting Unit and its charging system.

The contents of the Instruction manual for use and maintenance is supplemented by the following documents:

- “Arrangement of Controls” that contains the configuration of the Transmitting Unit and the names of the commands sent to the Receiving Unit;
- “Connection diagram” that indicates the correspondence of the commands sent by the Transmitting Unit and those available in the Receiving Unit.

The Instruction manual for use and maintenance is an integral part of the Elca Radio Remote Control and therefore of the Machine that is equipped with the Radio Remote Control. It is the responsibility of the Manufacturer of the Machine or the system on which the Radio Remote Control is installed to ensure that the Instruction Manual is inserted in the instruction manual of the Machine.

Further information on the operation of the radio remote control system, particularly if made to the customer's own specifications, can be found in the documents attached to the manual that should be considered as an integral part of the Manual itself.

1.2 Definitions

Please contact ELCA if any instructions, symbols, warnings or images are not clear or understandable and in case of doubts or questions. The “Manufacturer's identification” can be found on page 6 or with the QR Code here on the side.



The meanings of the terms in the entire Manual, including all its parts, are shown below:

Unit: the individual units, transmitting and receiving, that make up the Elca Radio Remote Control.

Radio Remote Control: wireless control system (CCS: Cableless Control System) composed of a Transmitting unit and a Receiving unit that communicate with each other via radio connection.

Transmitting unit: portable component (remote station) through which the user interfaces with the Radio Remote Control.

Receiving unit: component fixed stably to the Machine (base station) that constitutes an interface between the Radio Remote Control and the other parts of the machine.

Machine: the machine, as defined by Directive 2006/42/CE and by other local regulations, and every other device, machinery, equipment, system, application, etc., on which the Elca Radio Remote Control is installed or that is controlled by it.

Manufacturer: the entity that designs and/or constructs a Machine and that decides to install a Radio Remote Control in order to operate the Machine.

Installer: the entity, specialised technician, that plans and/or carries out the installation of the Elca Radio Remote Control on a Machine in order to operate its controls.

User: the entity that materially uses the Elca Radio Remote Control as a device for operating the controls of a Machine.

Maintenance technician: the entity, specialised technician, that carries out routine and extraordinary maintenance on the Elca Radio Remote Control, in order to keep it undamaged and running efficiently.

Manual or Instruction manual: document consisting of Part 1 (Transmitting unit and its charging system), Part 2 (Receiving unit), Position of the controls and the Connection diagram.

Person: individual, natural or legal person and/or every entity, however considered.

Owner: the owner of the Radio Remote Control.

The functions indicated for the Manufacturer, the Installer, the User and the Maintenance Technician can be carried out by a single entity, where these have the skills and assume the relative responsibilities. Each entity should be aware of the instructions in the Manual for the work that it carries out.

For example, if a Manufacturer also acts as an Installer, and/or Maintenance Specialist, it should understand and follow also the instructions specifically directed at these entities. The same criteria should be applied in the case where, for example, a User assumes the function of manufacturer and/or Installer.

1.3 Symbols

The parts of the Manual that are drawn attention to by this symbol should be read very carefully.

The parts of the Manual that are drawn attention to by this symbol contain warnings, information and/or instructions that are extremely important for safety issues: failure to understand these parts could be dangerous for Persons and/or property.

1.4 Who these instructions are for

The Instruction Manual is for the User, the Owner of the Radio Remote Control, the Installers, the Manufacturers and all those Persons who, for whatever reason, are operating the Radio Remote Control or the Machine on which it is installed.

The Manual should be read, understood and applied, in all its parts, by:

- the Owner and/or the person responsible for operating the Machine and/or the Elca Radio Remote Control;
- the Manufacturer of the Machine who decides to equip it with a Radio Remote Control;
- the Installer of the Radio Remote Control or the entity that takes care of its fitting on a Machine, on a device, on a system, etc., and/or that has the responsibility for its operation;
- the safety manager of the workplace where the Radio Remote Control is used;
- the Users, namely those who materially, and for any purpose, are enabled/authorised/entrusted with using the Radio Remote Control or simply find themselves in this situation;
- the Maintenance technician;
- Those who, for any reason, find themselves operating the Radio Remote Control and/or the Machine, the system, the device and/or the system on which the Elca Radio Remote Control is installed, or which is controlled by it.

The instructions concerning the installation and maintenance of the Radio Remote Control are for qualified personnel and for their application specialised professional expertise is required: none of the operations for which qualified personnel are required can be carried out by Persons or entities that do not have the specific professional skill required.

1.5 Storage of the instructions

The Instruction Manual should be taken good care of and should accompany the Radio Remote Control throughout its working life. No part of the manual should be removed, torn or arbitrarily modified.

The Instruction Manual should be available for all those requiring it and at any moment it becomes necessary to consult it.

Another copy of the Manual should be requested if it deteriorates. The copy will be supplied after communicating the serial number of the Radio Remote Control and at the expense of the person requesting it.

1.6 Updating the Manual

The contents of this manual are subject to change without prior notice, therefore the operator is required to verify (before using the radio remote control) that the information contained in this publication is consistent with the device in their possession. Elca is solely responsible for the instructions compiled and validated by Elca itself (Original Instructions); in order to be able to check the accuracy of the translation, any translations should always accompany the Original Instructions. Contact ELCA in the event there are instructions, warnings or indications which may prove to be unclear.

1.7 Intellectual property

This manual and any annexed documents are the property of ELCA and all rights are reserved. No part of this publication (for example the structure, the contents, the instructions, the figures, the diagrams, the photos) may be reproduced or transmitted (including photocopies and web) for any reason without the written authorisation of Elca.

2 Series, Radio Remote Control and Unit

The part of the Manual concerns the Receiving Unit of an Elca Radio Remote Control in the E1 series.

Elca Radio Remote Controls provide a control interface to be used on Machines to manage the command and control system.

The Radio Remote Controls have been designed to be used at a suitable distance and position.

The radio remote control in the series E1 consists of a transmitting unit and a receiving unit.

3 Conformity

It is the responsibility of the recipients of these instructions to:

- check the radio frequency band permitted in the country where it will be used;
- check that the Radio Remote Control operates inside this band;
- check the country's applicable standards;
- check that the Radio Remote Control operates correctly in conformity with them.

In no way can the conformity of the Radio Remote Control be modified, making changes to it or carrying out technical interventions that change the way it works.

For the instructions and use of the Elca Radio Remote Controls, local regulations must be respected.

These regulations obligate the protection of the conformity of the products with local regulations, and the specific standards regarding the safe use of the Radio Remote Controls or electric devices, both inside and outside the workplace.

3.1 EU conformity

One of the indispensable requisites for the Radio Remote Control have EU conformity is that it operates at one of the permitted frequencies, based on existing provisions in the European Union.

The Radio Remote Controls in the series E1 operate in the frequency band 434,050-434,790 MHz, therefore they are in conformity with Directive 2014/53/UE (RED) and its essential requirements.

Admission to the Radio Remote Control market is permitted since it conforms to harmonised rules in the EU declaration of conformity in force and applicable at the time this manual was printed.

The EU declaration of conformity of the Elca the Radio Remote Control is provided enclosed with the Radio Remote Control itself.

3.2 Countries of use

The Radio Remote Controls in the E1 range, which operate in the 434,050-434,790 MHz frequency band, can be used within the EU (European Union) and EFTA (European Free Trade Association).

4 Manufacturer's identification

Radio Remote Control Manufacturer	ELCA S.r.l.
Registered office	Via del Commercio, 7/b - 36065 Mussolente (VI) - ITALY
Telephone	+39 0424 578500
Fax	+39 0424 578520
E-mail	info@elcaradio.com
Site	www.elcaradio.com

5 Assistance and spare parts

For technical assistance and/or spare parts, please contact Elca. When sending a request regarding an Elca Radio Remote Control the serial number (Serial Num.) of the Radio Remote Control itself must be provided. The serial number (Serial Num) can be found on the Unit's data plate (see paragraph 11.3).

6 Warranty

The general warranty conditions can be found in the dedicated section of the website www.elcaradio.com.



7 Safety warnings

7.1 General information



All the warnings and instructions contained in this chapter are relevant for safety purposes.

Failure to follow the instructions in the Manual supplied by Elca and applicable safety legal provisions, also local, regulations, norms and standards can cause serious injuries to Persons and damage to property.

It is the responsibility of the Manufacturer and/or the designer of the Machine, the Installer, the Maintenance Technician and the Persons responsible for the use of the Machine and the workplace, that the installation, maintenance and use of the Elca Radio Remote Control and all its components are done only and entirely in compliance with the instructions provided by Elca e and in conformity with all applicable safety standards and regulations in force in the countries where the Machine and Radio Remote Control are used.

The Manufacturer of the Machine bears responsibility for the installation and use of Radio Remote Control on any application.

The Manufacturer of the Machine or whoever intends to use or install an Elca Radio Remote Control on a Machine should first of all:

- check whether the Machine that you want to equip with a Radio Remote Control is suitable for being used with a Radio Remote Control safely and efficiently;
- carry out a comprehensive risk assessment taking into contact the construction, functional and/or performance characteristics of the Machine, the use of the Machine, the location and the environment where the Machine will be used, the structure where the Machine will be or is installed, the interaction between the Machine and the other equipment and the personnel, the safety conditions when the Machine is operating, the effective and potential different conditions of use, the conditions that can be created after the installation of a Radio Remote Control and the characteristics and limitations of the Elca Radio Remote Control. To this end refer to, but not only, ISO 12100 and ISO 14121, that lay down the conditions through which a correct comprehensive risk analysis can be carried out as well as the adoption of the necessary safeguards.

Even without any legal or regulatory restrictions, a Radio Remote Control should never be used if the Manufacturer or those who intend to use or install a Radio Remote Control on a Machine cannot:

- carry out an appropriate and comprehensive analysis of the risks in relation to the safety of the Machine after the installation of the Radio Remote Control;
- provide adequate professional experience and/or technical expertise to properly carry out the risk analysis;
- correctly install the Radio Remote Control in accordance with this Manual and all the applicable Laws, Regulations and Standards, also local;
- implement all the safety provisions so that the machine fitted with the Radio Remote Control can be used safely without creating dangerous situations;
- adopt the appropriate technical remedies and actions from an information point of view to allow the User and Maintenance Technician of the Machine equipped with a Radio Remote Control to operate it safely;
- implement all procedures required and appropriate for eliminating or reducing the risks connected to using the Machine fitted with a Radio Remote Control.



THE INSTALLATION AND USE OF THE ELCA RADIO REMOTE CONTROL IS ONLY PERMITTED IF THE COMPREHENSIVE ASSESSMENT OF THE RISKS CONFIRMS THE INSTALLATION OF AN ELCA RADIO REMOTE CONTROL IS SUITABLE, EFFECTIVE AND SAFE FOR OPERATING THE MACHINE ITSELF, AND IF THE USE OF THE RADIO REMOTE CONTROL ON THE MACHINE IS PERMITTED BY AND IN CONFORMITY WITH APPLICABLE LAWS, REGULATIONS AND STANDARDS, ALSO LOCAL, AND WITH THIS MANUAL.

THE MANUFACTURER OF THE MACHINE OR THOSE WHO INTEND TO INSTALL AN ELCA RADIO REMOTE CONTROL ON A MACHINE IS RESPONSIBLE:

- FOR AN ASSESSMENT OF THE RISKS;
- FOR THE DECISION TO USE THE ELCA RADIO REMOTE CONTROL ON THE MACHINE;
- FOR IMPLEMENTING ALL THE NECESSARY OR ADVISABLE MEASURES FOR REDUCING OR ELIMINATING THE RISKS RESULTING FROM THE MACHINE AND, WITHOUT RESTRICTION, FROM THE USE OF THE RADIO REMOTE CONTROL FOR CONTROLLING THE MACHINE;
- FOR THE OBSERVANCE OF THE STANDARDS AND REGULATIONS AIMED AT MAINTAINING SAFETY.

THE ELCA RADIO REMOTE CONTROL IS NOT AN INDEPENDENT PRODUCT AND IS EXCLUSIVELY A COMPONENT OF A MACHINE THAT:

- PERMITS A RADIO REMOTE CONTROL TO BE USED IN AN APPROPRIATE MANNER,
- CAN BE OPERATED SAFELY AND IN COMPLIANCE WITH ALL LEGAL PROVISIONS, REGULATIONS AND STANDARDS APPLICABLE TO THIS RADIO REMOTE CONTROL.



ELCA IS NOT RESPONSIBLE FOR, AND DOES NOT ACCEPT ANY LIABILITY FOR, THE COMPATIBILITY BETWEEN THE RADIO REMOTE CONTROL AND THE MACHINE OR THE USE YOU WANT TO MAKE OF IT, IRRESPECTIVE OF WHETHER IT FALLS WITHIN THOSE ENVISAGED OR NOT, OR FOR ANY PROBLEM REGARDING THE SUITABILITY OF THE MACHINE AND ITS CONTROL SYSTEMS TO BE MANAGED USING THE RADIO REMOTE CONTROL.



IN THE SAME WAY ELCA IS NOT RESPONSIBLE FOR, AND DOES NOT ACCEPT ANY LIABILITY FOR, THE ASSESSMENT OF THE RISKS TO BE CARRIED OUT WHENEVER TAKING INTO ACCOUNT THE RADIO REMOTE CONTROL IN GENERAL, OR SPECIFICALLY THE ELCA RADIO REMOTE CONTROL, NOR FOR THE SUITABILITY OF OPERATING THE MACHINE WITH A RADIO REMOTE CONTROL IN GENERAL OR SPECIFICALLY THE ELCA RADIO REMOTE CONTROL, IN RELATION TO THE STRUCTURE WHERE THE MACHINE IS OR WILL BE USED, AS WELL AS THE ENVIRONMENTAL AND/OR OPERATING CONDITIONS IN WHICH THE MACHINE IS OR WILL BE USED.

Without limiting what was stated above, Elca is not responsible for, and does not accept any liability for:

- defective installation or installation not complying with this Manual, with any other instructions provided by Elca, and with all applicable Laws, Regulations and Standards, also local;
- installation carried out on Machines, appliances, devices, equipment and/or systems for which the use of a Radio Remote Control is not permitted by its Manufacturer or by applicable Laws, Regulations and Standards, also local, and for which the installation and/or use of a Radio Remote Control could cause safety issues or other hazardous situations that are not adequately eliminated and/or reduced, in respect of applicable Laws, Regulations and Standards, also local;
- the use of the Elca Radio Remote Control that does not comply with what is written in this Manual and in any other instructions supplied by Elca and with applicable Laws, Regulations and Standards, also local;
- the use of the Radio Remote Control in locations, climatic and/or weather conditions that are not permitted or not recommended by applicable Laws, Regulations and Standards, also local, forbidden by the instructions in this Manual, or in relation to which there are risks of damage and/or incorrect operation of the Radio Remote Control (for example: temperatures outside the limits indicated in the paragraph 10.3, situations with a risk of explosion, contact with liquids or fluids);
- the use of the Radio Remote Control in work conditions that do not allow the User to maintain complete and continuous visual control of the movements of the Machine and the load, if present;
- the use of the Radio Remote Control in a manner different to, or for uses other than those permitted and/or not in complete conformity with the instructions for use and maintenance contained in this Manual;
- the lack of, or poor maintenance of the Radio Remote Control, both routine and special, or the failure to repair any damage, wear or malfunction of the Elca Radio Remote Control;
- damage and/or deterioration of any part or function of the Radio Remote Control;
- failure to take the Elca Radio Remote Control out of service in the case it or one of its components develops a fault or malfunctions;
- the use of non-original parts or components that were not supplied by Elca;
- technical assistance for the Elca Radio Remote Control carried out by a company other than Elca or that is not part of its assistance network.

7.2 Risk analysis for remote-controlled Machines

The Manufacturer of the Machine on which you intend to install the Radio Remote Control and its designers need to carry out a careful and in-depth risk assessment to determine whether the Elca radio remote control is suitable for the safe and efficient use of the Machine, taking into account the conditions of use and the intended uses, and that the installation, maintenance and use of the Elca radio remote control and all its components are carried out only and entirely in accordance with this Manual and in compliance with all local safety rules, standards and regulations (referred to herein as "Laws, Regulations and Standards").

In carrying out the risk analysis to establish whether the Radio Remote Control can be installed on a Machine, the Manufacturer of the Machine and/or the Installer of the Radio Remote Control must respect all Laws, Regulations and Standards, also local, regarding the assessment of the risks and the safety of the Machine and the following recommendations:

- some Machines cannot be fitted with a Radio Remote Control, as established in paragraph 8.6). Also all the other circumstances that might limit, impede or impose conditions for the use of a Radio Remote Control on the Machine, or which could effect it being used correctly and safely should be evaluated.
- The radio link between the two Units can be interrupted (see paragraph 8.2.3).
- all the information regarding the installation, use and maintenance supplied by Elca should be taken into consideration (see paragraph 8.6 , paragraph 10 and paragraph 14).
- there is a delay between the release of a command in the Transmitting Unit and the deactivation of the relative output in the Receiving Unit (see paragraph 7.3).
- there is a delay between the activation of a command in the Transmitting Unit and the activation of the relative output in the Receiving Unit (see paragraph 7.3).
- additional measures might be needed to protect the actuators (see paragraph 7.4).
- it is possible that a command is activated or deactivated because of electrical and/or mechanical faults.

7.3 Delay in the command response time

In normal conditions, the delay between the activation of a command in the Transmitting Unit and the activation of the relative output in the Receiving Unit requires a time equal to the "Command response time" (typical) indicated in the Technical Data (see paragraph 8.3). In situations where there is a poor quality radio link (for example: interference, range of action reached) this delay can extend up to the "Maximum stop time" indicated in the Technical Data (see paragraph 8.3).

It should be remembered that due to the characteristics of the radio medium (for example: interference, range of action reached), the delay between the release of a command in the Transmitting Unit and the deactivation of the relative output in the Receiving Unit can extend up to the "Maximum stop time" indicated in the Technical Data (see paragraph 8.3).

The Manufacturer of the Machine, the Installer, the Owner, the User and the Maintenance Technician need to make sure that these delays can never lead to a situation of danger in the specific application.

7.4 Unintended activations of the commands

The User should operate the Radio Remote Control correctly, following the use and maintenance instructions.

If the Unit is used correctly, accidental contact with parts of the body of the User or with foreign objects, does not cause the unintended operation of the actuators.

Any action is carried out on the Transmitting Unit, or part of it, in order to operate the actuators in a way other than that indicated in the Manual is an incorrect use of the Radio Remote Control and cause serious damage to Persons and/or property.

The User should use the Radio Remote Control in compliance with the use and maintenance instructions and all applicable Laws, Regulations and Standards, also local, in the country where the Radio Remote Control and the Machine are used, always maintaining control of the Radio Remote Control and the position of use just as described in the specific part of the Transmitting Unit.

The Manufacturer of Machine and/or the Installer should assess and eventually adopt additional protective measures for the actuators (for example: two-hand controls, "dead-man" function) in the case where particular locations, equipment and working modes can create situations of risk and in the case this is required by the applicable Laws, Regulations and Standards in the country where the Radio Remote Control and the Machine are used.

It is possible that a command is activated or deactivated because of electrical and/or mechanical faults, which can affect the Radio Remote Control and/or the Machine.

The Manufacturer of the Machine and/or the Installer of the Radio Remote Control should carefully assess what the consequences of this malfunction are. If the risk analysis requires it, protective measures should be prepared that avert, reduce or signal situations of potential risk.

If a command is activated and/or deactivated because of electrical and/or mechanical faults:

- press the STOP button to put the machine in a safe state,
- disable the Radio Remote Control and cease using the "Machine+Radio Remote Control" system until the problem is solved by means of the required technical intervention.

8 Radio Remote Control of the Range

8.1 Characteristics

An Elca Radio Remote Control of the E1 series belongs to a family of industrial Radio Remote Controls, that can mainly be used, but not only, for controlling lifting and transportation apparatus.

With a Radio Remote Control it is possible to control the Machine from a remote position and without a physical connection using wifi or connection cables.

The User manages the machine from a distance using a Transmitting Unit (portable) that dialogues with a Receiving Unit (fixed) installed on the Machine itself.

This chapter contains images of the individual units that make up the Radio Remote Control, please look at the parts concerning each Unit.

8.2 Frequencies and radio link

8.2.1 Frequencies

The radio link between the Elca Radio Remote Control units in the E1 range occurs at one of the frequencies permitted under European regulations in force at the time when placed on the market.

The E1 range operates using the 434,050-434,790 MHz frequency band.

Depending on the specific market there are laws and regulations that establish the frequency with which a Radio Remote Control can operate.

If these laws and standards are not respected, the Radio Remote Control cannot and should not be used.

It is not the responsibility of Elca to check whether the Radio Remote Control is configured during installation and used with a frequency other than that permitted in the country where it is to be used.

The Radio Remote Control is made in such a way that when started it looks for a free frequency to use. The automatic search for a frequency allows a free frequency to be found free from interference. It also allows other apparatus in the vicinity not to be disturbed and vice-versa not to be disturbed by them.

8.2.2 Technical data of the frequency band

Data	Value
Frequencies used in the band	31
RF power	<10 mW ERP
Channel spacing used	25 kHz

8.2.3 Description of the radio link

The Transmitting Unit communicates with the Receiving Unit using a radio link.

The system uses electromagnetic waves to transport the control signals.

The Transmitting Unit and the Receiving Unit communicate through codified messages that contain a unique code.

Each unit can decode only the messages coming from the Unit that possess the same code. This is to exclude the possibility that another radio apparatus could send commands to the Machine on which the Radio Remote Control is installed.

Each Radio Remote Control operates within and not beyond a certain distance, beyond which the communication between the Units is lost. This distance is called "operating range".



The radio link is sensitive to particular conditions in the environment, like for example the presence of metal obstacles or electromagnetic interference.

If the connection between the Transmitting Unit and the Receiving Unit is interrupted or is incorrect, the system provides that the Receiving Unit commands the Machine to stop.

There are various reasons for an interruption of the connection:

- programmed automatic shut-off;
- Transmitting Unit low battery;
- no power supply to the Transmitting Unit;
- STOP button pressed;
- automatic connection interruption;
- operating range exceeded;
- presence of metal obstacles.

For the Machine to stop, however, the wiring between the units must have been made correctly.

When the radio link is interrupted all the outputs of the Receiving Unit are disabled. To be able to activate/deactivate the controls of the Machine using the Transmitting Unit the Radio Remote Control must be switched on again.

8.2.4 Stop

The shut-down is a safety function that puts the Machine in a safe state each time it is necessary to stop it because of a potentially dangerous situation.

The stop function can activate:

- by the operator pressing the red STOP button on the Transmitting Unit (manual mode).
- automatically by the Receiving Unit if the radio link between the Units is incorrect or interrupted (automatic mode).



THE USER MUST ALWAYS PAY THE UTMOST ATTENTION TO THE SAFE AND CORRECT WORKING OF THE MACHINE IN ACCORDANCE WITH THE INSTRUCTIONS AND WARNINGS PROVIDED IN THIS MANUAL, THE INSTRUCTIONS AND WARNINGS IN THE MANUAL OF THE MACHINE AND IN COMPLIANCE WITH ALL APPLICABLE LAWS, REGULATIONS AND STANDARDS, ALSO LOCAL.

THE ACTIVATION OF THE STOP BUTTON OR THE RETURN OF THE ACTUATORS TO THE REST POSITION MIGHT NOT CAUSE THE MACHINE TO STOP IMMEDIATELY.

THE STOP BUTTON MIGHT NOT ACTIVATE A BRAKE. MOREOVER, DIFFERENT MACHINES HAVE DIFFERENT RESPONSE TIMES AND STOPPING DISTANCES. EVEN IF THE STOP FUNCTION IS USEFUL, THE USER SHOULD BE FULLY AWARE OF THE MOVEMENTS AND WORKING AREAS OF THE MACHINE AND SHOULD PROVIDE FOR THE SAFE OPERATION OF THE MACHINE, TAKING INTO CONSIDERATION THESE RESPONSE TIMES AND STOPPING DISTANCES.

FAILURE TO COMPLY WITH THESE INSTRUCTIONS, EVEN TEMPORARILY, CAN CAUSE SERIOUS INJURIES OR DEATH OR DAMAGE TO PROPERTY.



The stop function using the Radio Remote Control is only available if the Radio Remote Control has been started.



Never leave the Transmitting Unit unattended so that there is no doubt about the availability of the stop function.

The "useful life", as defined in international standards and requirements, of the stop function is 20 years. In any case, the Radio Remote Control should be replaced before then. The "useful life" cannot be understood as a warranty period.

After the STOP button is activated in the Transmitting Unit, the Machine is no longer controlled by the Radio Remote Control. The possible risks deriving from the activation of the stop function should be evaluated both by the Installer of the Radio Remote Control as well as by the Manufacturer and the Owner of the Machine on which the Radio Remote Control is installed. The User of the Radio Remote Control should be adequately trained in this regard.

8.3 Technical data of the range

Data	Value
Operating range	150 m
Command response time (typical)	<100 ms
Stop time (typical)	100 ms
Maximum stop time	0.5 s
Performance Level of the "stop protection" according to ISO 13849-1	Cat. 3 PL d

The technical data of the Transmitting Unit in the E1 range are reported in Part 1 e and in the relative Position of Controls and Connection Diagram.

8.4 Identification of the Radio Remote Control

The serial number (Serial Num.) uniquely identifies the Radio Remote Control.

The serial number can be found on the data plate of the Radio Remote Control; each unit of the Radio Remote Control has its own data plate.

When sending a request regarding an Elca Radio Remote Control the serial number (Serial Num.) of the Radio Remote Control itself must be provided.

The Serial Num. should be reported in all communications with Elca or with Persons who require information, spare parts or technical data regarding the Radio Remote Control.



Do not remove the data plate on the Units from their position, since removing it will immediately void the warranty. If the data plate has been altered or damaged, contact Elca for a replacement.

8.5 Transportation and/or storage

The Radio Remote Control and all its parts should be transported and stored according to the following parameters and environmental conditions:

Operation	Temperature
Transportation	from -25°C to +55°C
Storage	from -25°C to +55°C

The original packaging should be kept for the entire life of the product.

Use the original packaging for transporting and storing the Radio Remote Control in all the phases of its life, for example before installing and after its removal.

8.6 Applications

An Elca Radio Remote Control of the E1 range can be used for various applications: the suitability of the Radio Remote Control for each different application, especially for safety reasons, should be assessed by the Manufacturer of the Machine.

The E1 range is most often used on Machines for lifting and moving materials, objects, and loads in general (for example: overhead travelling crane, lifting crane, etc.) if permitted by the instructions in this Manual.



An Elca Radio Remote Control should not be installed on Machines whose application or function is not permitted by this Manual or by applicable Laws, Regulations and Standards, also local.

THE INSTALLATION OF AN ELCA RADIO REMOTE CONTROL ON OTHER MACHINES OR FOR OTHER FUNCTIONS CAN CAUSE SERIOUS INJURY OR DEATH OR DAMAGE TO PROPERTY.

Elca is not responsible for, and does not accept any liability for, applications of the Radio Remote Control in situations where safety conditions are poor or non-existent.

The Manufacturer of Machine should assess and eventually adopt additional protective measures for the actuators (for example: two-hand controls, "dead-man" function) where particular locations, equipment and working modes can cause accidental collisions.

In addition to the above, a E1 Radio Remote Control should not be installed:

- On Machines operating in environments that require explosion-proof equipment, or in all those situations that carry a risk of explosion.
- On Machines for moving, lifting and transporting Persons, where the characteristics of the Machine to be used for these functions and the risks connected to them and/or connected to the use of a Radio Remote Control do not allow the Manufacturer of the Machine to guarantee compliance with all safety requirements. These requirements should be taken into consideration when designing and manufacturing the Machine, also taking into account the use of the Radio Remote Control. The Manufacturer of the Machine can allow the installation and use of the Radio Remote Control on these applications under its own responsibility.
- On Machines that cause or might cause dangerous situations in the event of a stoppage due to the loss of the radio link.
- On Machines that, because of their functions or characteristics and/or risks connected to their use, do not allow the use of a Radio Remote Control in conditions where there are no risks.
- On any type of lifting equipment (for example: magnets, pliers, suction cups) when the loss of the radio link or the deactivation of the controls can cause the release of the load being held, with the risk of harming Persons and/or damaging property. The Manufacturer of the Machine can allow the installation and use of the Radio Remote Control for these applications under its own responsibility.
- If the applicable legislation in the country where the Machine is used, and also the local safety regulations and standards, also with reference to safety in the workplace, do not allow the use of Radio Remote Controls for commanding and/or controlling Machines.

THE INSTALLATION OF AN ELCA REMOTE RADIO CONTROL ON MACHINES AND IN SITUATIONS DESCRIBED ABOVE CAN CAUSE SERIOUS INJURIES OR DEATH OR DAMAGE TO PROPERTY.

8.7 Training of the personnel: Installation and maintenance

All the installation and maintenance operations on the Elca Radio Remote Control should be carried out ONLY by qualified personnel. Without limiting the foregoing, the qualified technical personnel should be trained and qualified in relation to:

- the work to be carried out;
- the warning deriving from the risk analysis connected to the installation and/or maintenance of the Radio Remote Control;
- all the applicable Laws, Regulations and Standards, also local, including also safety aspects;
- the operation and the requisites of the Machine on which the Radio Remote Control is installed;
- the warnings and the instructions in this Manual and in other documentation of the Radio Remote Control and the Machine fitted with the Radio Remote Control;
- the instructions of the Manufacturer of the Machine and the person responsible for safety in the workplace where the "machine+Radio Remote Control" system is used.

8.8 Classification of the controls

This paragraph describes the classification of the controls in the Radio Remote Control: this information is useful during installation and maintenance.

Type of control: analogue or digital

The commands sent by the Transmitting Unit can be either analogue or digital.

An analogue command generates a proportional output depending on the position of the relative actuator.

A digital command switches the state of the relative output according to the position of the corresponding output. This state can be on or off.

Name of the commands

All the commands sent by the Transmitting Unit are identified with initials.

These initials are reported in the Position of the controls and in the Connection diagram to be used during installation.

These documents clarify the correspondence between the commands sent by the Transmitting Unit and those available in the Receiving Unit.

9 Warnings for the installation



All the instructions and warnings of the Elca Radio Remote Control in this Manual should be read and understood. Failure to understand or follow them can cause serious injuries or death or damage to property.

The Installer of the Radio Remote Control should always read, understand and comply with all the instructions and warnings contained in all the sections of this paragraph.

These instructions and warnings are not exhaustive. In addition, in order to carry out a correct installation, the Installer must comply with and respect all the applicable Laws, Regulations and Standards, also local including all the technical specifications and regulations applicable to the Elca Radio Remote Control to which this manual refers (for example: IEC 60204-1, IEC 60204-32).

The Installer of the Radio Remote Control should also comply with all the technical instructions, requirements and provided by the Manufacturer of the Machine.



A correct installation requires that the indications provided in the Connection diagram and in the Position of the Controls and the values in the technical data should always be respected.

The electrical connection of the Receiving Unit should satisfy the requirements of article 9.1 of IEC 60204-1 and/or IEC 60204-32.

ONLY QUALIFIED PERSONNEL CAN INSTALL THE RADIO REMOTE CONTROL. THEY SHOULD HAVE THE TECHNICAL ABILITIES REQUIRED FOR CARRYING OUT THESE OPERATIONS CORRECTLY AND SAFELY, SHOULD BE QUALIFIED ACCORDING TO LEGISLATION AND REGULATIONS, AND SHOULD HAVE ALL THE NECESSARY CERTIFICATIONS.

AN INCORRECT INSTALLATION OF THE ELCA RADIO REMOTE CONTROL CAN CAUSE SERIOUS PHYSICAL INJURIES OR DEATH AND/OR DAMAGE TO PROPERTY.

9.1 Warnings for the Installer

In addition to all information made available by the Machine Manufacturer, the Installer should always take the following precautions:

- understand and comply with all the technical and warning provided by the Manufacturer of the Machine;
- carry out a thorough risk assessment considering the use of the Machine with the aid of the Radio Remote Control.
- implement and comply with the provisions of the reference standards for the field of application of the Machine on which installation is being carried out;
- understand and comply with all the applicable Laws, Regulations and Standards, also local;
- comply with all the warnings and instructions given by the person in charge of starting up the Machine and preparing it for work;
- comply with all the indications and warnings contained in the Manual of the Radio Remote Control;
- use the Elca Radio Remote Control only as indicated in this Manual and in all the instructions provided by Elca;
- use the Machine on which the Elca Radio Remote Control is installed only in safe conditions and only if it is possible to get a good view of the working area of the Machine;
- check that there are no hazardous conditions in the event the Radio Remote Control stops due to the loss of the radio link;
- prevent the use of the machine when there are problems, faults, wear or breakages;
- immediately inform your superiors and/or workplace and/or Machine managers of any faults that could cause the Radio Remote Control and/or the Machine to malfunction or that could be a cause of injury to Persons and damage to property;
- keep the Transmitting Unit safe so that it cannot be used by unauthorised or unqualified personnel;



COMPLY WITH THE ADDITIONAL WARNINGS AND INSTRUCTIONS THAT ARE CONTAINED IN OTHER PARTS OF THIS MANUAL.

9.2 Positions and mounting of the Receiving Unit

Position the Receiving Unit so that it is easily accessible. Position the Receiving Unit so that it is as far away as possible from metal parts (at least 50 cm) and never inside metallic or conductive materials.

Position the Receiving Unit vertically, with the cable gland or plug facing down.

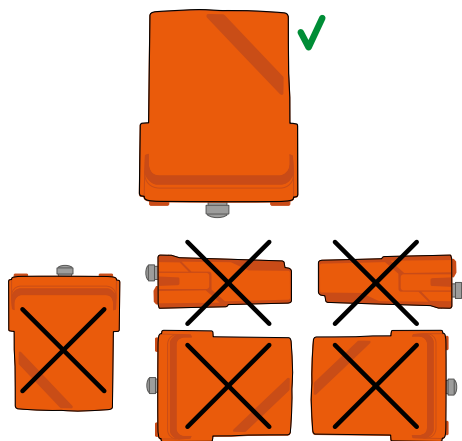

When installing on Machines that are subject to heavy stresses (for example: vibrations, rocky terrain, sudden movements), we recommend fixing the Receiving Unit to the Machine with vibration dampers.

9.3 Receiving Unit wiring

By wiring is meant the electric connections using cables and that are made inside the Receiving Unit or between the Machine and the Receiving Unit.

In the wiring phase it is necessary to:

- avoid exposing the Receiving Unit to strong vibrations, if necessary using appropriate vibration dampers;
- connect the Receiving Unit to the machine using multi-pole connectors so that it can be easily disconnected if it needs to be sent to a service centre;
- for the wiring, use cables of a suitable diameter max. 2.5 mm² terminated with wire clips or terminals;
- the power supply of the Receiving Unit must be protected against short circuits;
- always make sure that the value of the supply voltage complies with the rated voltage indicated on the data plate of the Receiving Unit.
- provide for the possible disconnection of the power supply to the Receiving Unit during installation, wiring and maintenance operations;
- pay attention to the current in the STOP and SAFETY relays so that it never exceeds the permitted value of 4A;
- the SAFETY relay contact must be connected in series with the common wire of the movement commands when the safety protection is required in relation to the involuntary activation of the control with actuator at rest;
- connect the two STOP contacts in series, connecting COM STP1 with STP2 with a jumper when the Machine is setup for a single Stop command (Stop contact is now between terminals COM STP2 and STP1);
- it is IMPERATIVE that the two STOP contacts on the Receiving Unit are always used;
- connect the two STOP contacts separately if the Machine is set up to manage two separate Stop contacts (use four wires). The Installer is responsible to carry out the wiring able to guarantee the level of safety required;
- join the wires together by means of binding, making sure that the wires are far away from the electronic module and are sufficiently fastened so they remain stationary even if released from the connector, and avoid potential hazards related to electrical safety.

When the installation is finished, it is necessary to:

- test the machine operated by the Radio Remote Control, checking the actual safety of the machine by means of the STOP command, the exact correspondence of the command symbols with the actual movement of the machine;
- check that during the installation operations were not carried out that render the Machine's safety systems ineffective (limit switches, interlocks, load limiters, etc.);
- check that the contact of the SAFETY command is in series with all commands to which protection is required;
- check also that the Machine operates correctly the without the use of the Radio Remote Control where possible;
- if abnormal operations are experienced, DISABLE the Machine until the problem s completely resolved;
- close the Receiving Unit checking firstly whether the gasket in the cover is undamaged.

9.4 Positioning the antenna

If the antenna is located inside the Receiving Unit, install the Receiving Unit in a free area of the machine that is easy to reach, with no guards, panels, parts, surfaces or the like that act as shields, structures or materials that do not obstruct the radio link. In particular the Receiving Unit should be positioned not less than 50 cm from surrounding metal objects and should never be located inside closed metal containers.

If the Receiving Unit is covered by metal structures or installed inside metal panels, use the relative extension kit for the antenna. If the antenna extension kit is used, follow the instructions below.

Install the antenna in a vertical position, in a free area of the Machine, not having any guards, panels, parts surfaces or the like that act as shields, structures or materials that obstruct the radio link.

10 Instructions for the User

All the instructions and warnings of the Elca Radio Remote Control in this Manual should be read and understood. Failure to understand or follow them can cause serious injuries or death or damage to property.

10.1 Use of the Radio Remote Control and operating conditions

For the correct use of the Radio Remote Control all the warnings and instructions in the Manual must be respected. It is also necessary to comply with what is reported in the documentation of the Radio Remote Control and the Machine on which the Radio Remote Control is installed.

It is necessary to comply with all workplace safety and accident prevention regulations.

Finally, all applicable Laws, Regulations and Standards, also local, must be respected.

Below are some examples of behaviours to be avoided in using the Radio Remote Control.

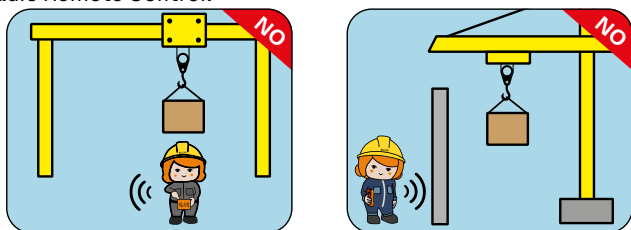

These examples are given purely by way of example and do not cover all possible incorrect uses of the Radio Remote Control.

It is the responsibility of the Manufacturer of the machine and the User to evaluate and establish any measures for avoiding the possible incorrect use of the Radio Remote Control or the Machine.

10.2 General warnings for the User

The User should:

- check that the units of the Radio Remote Control are undamaged and operational;
- check that the STOP button is working correctly;
- check that the controls of the Machine are working correctly;
- immediately notify superiors and/or managers of the workplace and/or the Machine of any faults, subsidence, deterioration of any other fault that could cause the Radio Remote Control and/or the Machine to malfunction or that could injure Persons and/or damage property;
- not the Radio Remote Control if it is damaged or if the controls are not working correctly;
- use the Machine on which the Elca Radio Remote Control is installed only in safe conditions and only if it is possible to get a good view of the working area of the Machine;
- use the Machine on which the Elca Radio Remote Control is installed only in accordance with the measures and instructions provided by the Manufacturer of the Machine and in compliance all applicable Laws, Regulations and Standards, also local;
- turn off the Transmitting Unit whenever work is suspended, even momentarily;
- respect all the instructions and warnings provided by the Manufacturer of the Machine and/or the Installer;
- respect all the instructions and warnings provided by the person responsible for starting up the Machine for work;

- respect all the instructions and warnings contained in the Manual of the Radio Remote Control;
- use the Radio Remote Control only as described in this Manual, as explained in all the warnings and instructions provided by Elca and in any event not contrary to all the applicable Laws, Regulations and Standards, also local;
- be aware of its work application and as a consequence implement all the operating instructions received in relation to that;
- use the Radio Remote Control only if in a good mental and physical condition;
- use the Radio Remote Control to move the Machine correctly;
- use the stop devices of the Radio Remote Control or the Machine if any dangerous situation arises, also unrelated to the use of the Machine;
- pay attention to the indicator lights of the Transmitting Unit;
- respect any safety distances connected to the use of the Machine in order to avoid potential and/or real situations of risk.

The User should not:

- use the Radio Remote Control if not fully aware of the instructions and warnings of the Radio Remote Control or if no suitable training has been received from qualified personnel;
- use the Radio Remote Control if you suspect a malfunction of the Radio Remote Control, the Machine or a component;
- use the Radio Remote Control if the labels, symbols and/or the warnings are dirty, worn or illegible;
- use the Radio Remote Control in conditions that do not allow the Transmitting Unit and/or the Machine to be controlled correctly;
- use the Radio Remote Control and carry out other operations, like for example using other Machines and/or other devices (telephone, computer, keyboards, information technology or audio-visual appliances, radio-telephone etc.);
- eat or drink when using the Radio Remote Control;
- alter the labels, the warnings and everything on the Receiving Unit;
- allow unauthorised persons and/or those who are not adequately trained to use the Radio Remote Control;
- leave the Receiving Unit exposed to the possibility of being used, damaged or tampered with by unauthorised persons.

COMPLY WITH THE ADDITIONAL WARNINGS AND INSTRUCTIONS THAT ARE CONTAINED IN OTHER PARTS OF THIS MANUAL.

10.3 Environmental conditions of use

The environmental conditions of use of the Elca Radio Remote Control are the following:

Unit	Temperature
Receiving Unit	from -25°C to +55°C

10.4 Warnings before starting work

Before starting work with the Radio Remote Control the User should:

- get in a position that allows both direct control of the Machine and also the movement of the load;
- get in a safe position with respect to the load, the Machine and any other activity, operation of the workplace;
- move to a work position where there is no risk of losing balance or tripping;
- check that the STOP button mechanism is working correctly;
- use the Radio Remote Control only for its intended use or for operating requirements;
- learn the correspondence between the actuators and the operations of the Machine.

The User should not:

- switch on or use the Radio Remote Control in enclosed spaces or places with poor visibility;
- use the Radio Remote Control if it is outside the operating range.

!
Failure to comply with the points above can lead to a connection between the Units of the Radio Remote Control that is not optimal, with the risk that the Machine carries out undesired commands.

A	Rating plate
B	Serial number
C	Cable gland or plug
D	Control cable connector
E	Slot for extension boards
F	STOP contacts protection fuses (F1-F2)
G	STOP outputs
H	SAFETY outputs
J	Bracket stoppers
K	Connector for AC power supply
L	AC power supply protection fuse
M	START outputs
N	SAFETY contacts protection fuses (F3-F4)
P	Connector for the receiver radio module
Q	Slot for the FEEDBACK board
R	Signalling LED connector (+12V - Status - Power)
S	DIP switch
T	STATUS LED and POWER LED
U	Receiver radio module

10.5 Warnings during normal use

!
During normal use the User should:

- pay attention to the work area and any dangerous situations present;
- visually check all the movements of the Machine and the load;
- stay within the operating range of the Radio Remote Control;
- pay attention to the visual and acoustic signals of the Radio Remote Control;
- use the Radio Remote Control to move the Machine safely, to avoid creating dangerous situations for Persons and/or property;
- switch off the Transmitting Unit and disconnect the power supply to the Receiving Unit in the event of a malfunction;
- immediately notify superiors and/or managers of the workplace and/or the Machine of any malfunctions;
- use the Radio Remote Control only after solving and problems and/or malfunctions;
- use the Radio Remote Control only with a fully charged battery;
- end any dangerous operations as soon as possible in the event of a low battery.

10.6 Warnings for after its use

!
Warnings for after its use

- avoid leaving the Machine in dangerous conditions (for example with a suspended load);
- prevent unauthorised or unsuitable trained persons from using the Radio Remote Control.

FAILURE TO COMPLY WITH THESE INSTRUCTION SCAN CAUSE SERIOUS INJURIES OR DEATH AND/OR DAMAGE TO PROPERTY.

11.1 Technical data

Radio transceiver module	MR32EL
Antenna	incorporated
Power supply	48/55/115/230 V [50/60Hz]
Current draw	330/280/140/70 mA
Absorbed power	<18 VA
Power supply input protection fuse	F5 = T 500 mA L 250 V
STOP contacts protection fuses	F1, F2 = T 4 A L 250 V
SAFETY contacts protection fuses	F3, F4 = T 4 A L 250 V
Maximum rated current of the control circuit contacts	10 A
Maximum rated current of the STOP circuit contacts	4 A
Maximum rated current of the SAFETY circuit contacts	4 A
Maximum contact voltage	230 V [50/60 Hz]
Protection degree	IP65
Dimensions	227x276x105 mm
Weight	2600 g

11 Description of the Receiving Unit

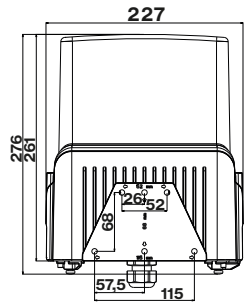
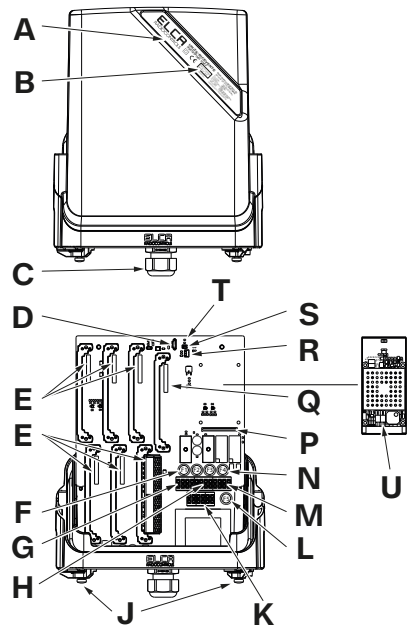

11.2 The Position of the controls and Connection diagram

The documentation supplied with the Radio Remote Control consists of:

- "Arrangement of Controls" that contains the configuration of the Transmitting Unit and the names of the commands sent to the Receiving Unit;
- "Connection diagram" that indicates the correspondence of the commands sent by the Transmitting Unit and those available in the Receiving Unit.

The Connection diagram should be checked, filled out and signed by the Installer who is responsible for carrying out the wiring correctly. The Position of the controls and the Connection diagram should always remain attached to this Manual: if you have to use one or more of these documents for administrative purposes (controls, tests, etc.) a copy should be made.



The wiring of the outputs of the Receiving Unit should always correspond to what is indicated in the Position of the controls and the Connection diagram.

11.3 Receiving unit data plate

There is just one Data plate on the Receiving Unit AR E1-MAXI.A. Its position and the information contained in it can be found in the table below:

Table	Position	Information
Unit plate	Cover of the Receiving Unit	Serial number, year of manufacture and the main technical data of the unit, the mark and any radio remote control marks.

11.4 Indicator lights

The Receiving Unit boards contains:

- the POWER LED
- STATUS LED

The meaning of the LED coming on is described in the tables below.

11.4.1 POWER LED

SIGNAL	MEANING
The POWER LED is off.	The Receiving unit is off.
The POWER LED is on.	The Receiving unit is powered.

11.4.2 STATUS LED

SIGNAL	MEANING
The STATUS LED flashes once every 5 seconds.	The Receiving unit is in stand-by. No radio link is active.
The STATUS LED flashes quickly.	The radio link is present.

11.5 Extension card

The following extension cards are available for this receiving unit:

- 8 relay expansion card
- PWM 6CH proportional card
- 6CH analogue proportional card
- 6CH analogue proportional card with current loop

11.5.1 Slot and outputs positions

Depending on the position of the extension slot, the outputs are as follows:

- EXP-1 the relay board has K0-K7
- EXP-2 the relay board has K8-K15
- EXP-3 the relay board has K16-K23
- EXP-4 the relay board has K24-K31
- EXP-5 the relay board has K32-K39
- EXP-6 the relay board has K40-K44



If it is a proportional board, it must be installed as the last board and there shouldn't be any free slots.

If, for example, there are 3 relay boards and one proportional board, the relay boards will be connected to the EXP-1, EXP-2 and EXP-3 slots, while the proportional board must be connected to the EXP-4 slot.

11.5.2 8 relay extension card

The 8 relay expansion card allows to expand the function of the system so as to obtain eight additional on/off outputs.

Number of available On/Off outputs	8
Maximum contact voltage	230 V~
Maximum rated current of the control circuit	10 A

11.5.3 PWM 6CH proportional card

The PWM 6CH proportional card has up to 6 proportional current outputs (PWM) and up to 3 digital inputs.

Outputs' power supply voltage	8-30 V $\overline{\text{---}}$
Number of available proportional current outputs (PWM)	6
Adjustable proportional current outputs (PWM)	from 0 to 2A (30V $\overline{\text{---}}$)
Number of available digital inputs	3
Voltage of the digital inputs	10-24 V $\overline{\text{---}}$

11.5.4 6CH analogue proportional card

The 6CH Analogue proportional card has up to 6 proportional voltage outputs (PWM) and up to 3 digital inputs.

Outputs' power supply voltage	8-30 V $\overline{\text{---}}$
Number of available proportional voltage outputs	6
Proportional voltage outputs (adjustable)	from 0 to 28 V $\overline{\text{---}}$ (10 mA) a
Number of available digital inputs	3
Voltage of the digital inputs	10-24 V $\overline{\text{---}}$

- a. The proportional voltage outputs can reach a maximum value of 2V lower than the power supply voltage of the outputs.

11.5.5 6CH analogue proportional card with current loop

The 6CH Analogue proportional card with current loop has up to 6 proportional voltage or current outputs (max 20mA) and up to 3 digital inputs.

Number of available proportional outputs	6
Proportional voltage outputs	from -10 to 10 V $\overline{\text{---}}$
(impedance \geq 1kOhm; power supply active)	
Proportional "current loop" outputs	max 20mA
(impedance \leq 500 Ohm; 2 wires, power supply active)	
Number of available digital inputs	3
Voltage of the digital inputs	10-24 V \approx

11.5.6 FEEDBACK inputs board with 2 exchange relays

The board allows 4 inputs for Feedback signals and 2 exchange contacts relays.

Feedback input voltage	9-48 V \approx
Number of available inputs	4
Relay control input voltage	9-48 V \approx
Maximum current on the relay contacts	10A

12 General operating instructions

The Receiving unit AR E1-MAXI consists of three main parts:

- MOTHER BOARD
- RADIO RECEIVING MODULE
- BOARD WITH THE IDENTIFICATION CODE

12.1 Mother Board

Contains the STOP, SAFETY and command relays, the terminals for the electrical connection, the power supply stage and the support with the electrical connection of the radio receiving module.

12.2 Radio receiving module

Contains all the electronics for the reception, the decoding of the commands transmitted from the transmitter and the identification of the system. The card with the identification code is installed on the radio receiver module.

12.3 Board with identification code

Contains the unique identification code of the system. This code allows the system to recognise the signals transmitted from the Transmitting Unit to which it is paired. The operating data of the system is also stored on this card.

12.4 DIP switch

DIP switch 1 should always be set to OFF.
DIP switch 2 should always be set to OFF.



The positions of DIP switch 1 and DIP switch 2 should not be modified for any reason during normal use.

The positions of the DIP switches can be modified in certain situations only by suitably trained and qualified technicians.

12.5 Command outputs

For the correspondence between the output activated on the Receiving Unit by a command given by the Transmitting Unit refer to the Position of Controls and the Connection Diagram.

13 Installation

The chapter “Warnings for the Installer” in this manual contains information and warnings for the installation that complete this chapter. It is therefore necessary to read, understand and be familiar with what is described in both chapters of this manual.



The installation must be carried out by qualified and authorised personnel in compliance with all applicable Laws, Regulations and Standards, also local.

The Installer must:

- respect the instructions and warnings of the Manufacturer of the Machine;
- comply with the provisions of the reference standards for the field of application of the Machine;
- comply with the contents of this manual;
- use the Machine on which the Radio Remote Control is installed only in safe conditions;
- use the Radio Remote Control to control the Machine only if the working area of the Machine is clearly visible;
- immediately switch off the Machine and disconnect the power supply to the Radio Remote Control and to the Machine if there are faults or problems with the Radio Remote Control or the Machine;
- immediately inform one's superiors and/or managers if there are faults, breakages or any other type of problem;
- keep the Transmitting Unit in such a way that unauthorised and/or unqualified personnel cannot use it.

13.1 Receiver unit fastening

The Receiver unit must be fastened to the Machine using the specific bracket.

To fasten the Receiver unit, follow the procedure below:

- rotate by approximately 90° the two bushings located on the lower part of the Receiver unit and remove the bracket of the unit;

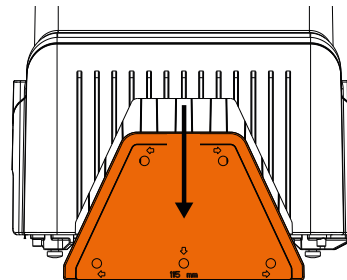
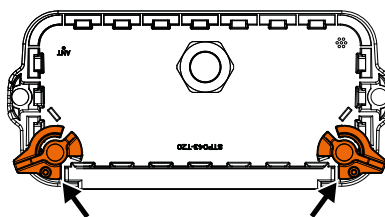

- fasten the bracket to the Machine calculating a buffer area according to the indications in the measurements:
 - [A] to allow the possibility to remove the receiver from the fastening bracket;
 - [B] to allow the possibility to remove the box cover without having to disconnect the receiver from the fastening bracket.

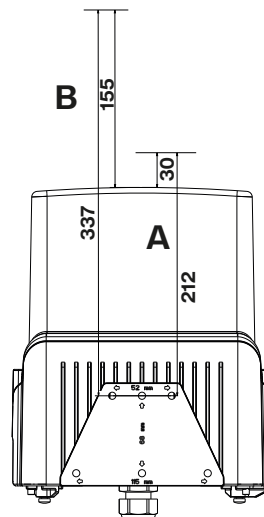

- insert the Receiver unit on the bracket;
- close the bushings to fasten the Receiver unit on the bracket.

13.2 Wiring indications

In the wiring phase it is necessary to:

- pay attention to the current in the STOP and SAFETY relays so that it never exceeds the permitted value of 4A.
- it is IMPERATIVE that the two STOP contacts on the Receiving Unit are always used;
- connect the two STOP contacts in series, connecting COM STP1 with STP2 with a jumper when the Machine is setup for a single Stop command (Stop contact is now between terminals COM STP2 and STP1);
- join the wires together by means of binding, making sure that the wires are far away from the electronic module and are sufficiently fastened so they remain stationary even if released from the connector, and avoid potential hazards related to electrical safety.

The SAFETY relay contact should be connected in series to the common wire of the movement commands when it is necessary to protect against unwanted movements from the rest position.

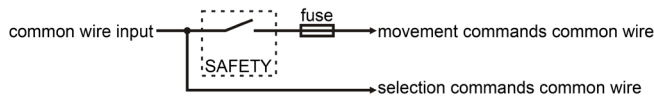

In the Receiving Unit the STOP circuit is made with two contacts connected in series by means of a wire jumper (standard Elca wiring).
if the Machine requires a STOP circuit with two separate contacts (four wires) this jumper can be removed. In this case the Installer is responsible for carrying out wiring that can provide the level of safety required.

When the installation is finished check that during the installation no operations have been carried out render the protection measures of the Radio Remote Control and/or the Machine ineffective.

To protect the Receiving Unit from dust, water and other substances the Receiving Unit should be closed, making sure that the gasket is correctly positioned and undamaged.
Make sure also that the parts connect and overlap so it closes correctly.

13.3 Testing

After installation, it is the responsibility of the Installer to test the radio-controlled Machine. In particular make sure that the command sent and the movements carried out match.
When checking pay particular attention to the STOP command, which should operate correctly.
If any malfunctions occur doing testing, both the Radio Remote Control and the Machine should be disabled until the problem is identified and rectified.

The Installer should check and fill out all the parts of the Connection Diagram and the Position of the Controls (if not pre-compiled). These documents must contain the date the system was commissioned, and the stamp and signature of the Installer.

14 Maintenance

14.1 Maintenance of the Radio Remote Control - general instructions

It is the responsibility of the Maintenance Technician:

- keep the Transmitting Unit safe so that it cannot be used by unauthorised or unqualified personnel;
- use the Machine on which the Elca Radio Remote Control is installed only in safe conditions and only if it is possible to get a good view of the working area of the Machine;
- use the Machine on which the Elca Radio Remote Control is installed only in accordance with the measures and instructions provided by the Manufacturer of the Machine and in compliance all applicable Laws, Regulations and Standards, also local;
- immediately notify superiors and/or managers of the workplace and/or the Machine of any faults, subsidence, deterioration of any other fault that could cause the Radio Remote Control and/or the Machine to malfunction or that could injure Persons and/or damage property;
- respect all the instructions and warnings provided by the Manufacturer of the Machine and/or the Installer;
- respect all the instructions and warnings provided by the person responsible for starting up the Machine for work;

- respect all the instructions and warnings contained in the Manual of the Radio Remote Control;
- all applicable Laws, Regulations and Standards, also local, must be respected;
- use the Radio Remote Control only as described in this Manual, as explained in all the warnings and instructions provided by Elca and in any event not contrary to all the applicable Laws, Regulations and Standards, also local.

All set up, control and maintenance operations of the Radio Remote Control must be recorded. The person responsible for the Maintenance of the Machine should record them.

Before carrying out any maintenance, it is necessary that:

- the Receiving Unit is NOT powered;
- the Transmitting Unit is off;
- the STOP button is pressed.

In the event of a malfunction the Transmitting Unit should be switched off and the Receiving Unit disconnected from the power supply. The Radio Remote Control must remain disabled until the problem is solved with the necessary technical interventions.

After each maintenance operation, it is necessary to:

- check that the gasket is undamaged and correctly positioned;
- check that the parts of the casing are properly connected so that they overlap;
- screw in the screws.

After each maintenance operation, always check that all the commands sent by the Transmitting Unit activate only the movements expected.

14.2 Routine maintenance

By routine maintenance is meant all those actions that have the single aim of maintaining the normal operating conditions of the Radio Remote Control.

Routine maintenance takes place through set up and control interventions, and the scheduled replacement of parts, required by a normal use of the product.

Each time that the Radio Remote Control is fitted or installed on the Machine, each time that the Machine is moved or placed in a new position or else after special maintenance, it is necessary to carry out all the instructions below.

The routine maintenance contained in this Manual is crucial for the safe operation of the Radio Remote Control.

In order for the Radio Remote Control to operate safely, the routine maintenance described in this Manual must be carried out.

Routine maintenance can requires specific interventions or be required to be carried out at different times if there are particular climatic conditions (for example: environments with very high or very low temperatures, very dirty environments or when frequently used).

Some specific interventions can be required more frequently by the Manufacturer of the Machine or by the Installer, whenever it is necessary.

Before carrying out any maintenance on the Machine, the Receiving Unit must be disconnected from the power supply.

14.2.1 Daily routine maintenance

What to do during normal use:

- prevent materials depositing on the Receiving Unit that could compromise its safe use (for example: dust, grease, concrete, lime, sand, etc.);
- avoid any action that could damage the Receiving Unit (contact with water, fluids and liquids, falls, bumps, etc.);
- protect the receiving Unit from jets of water or heavy rain;
- do not leave the receiving Unit unnecessarily exposed to direct sunlight or heat sources.

14.2.2 Monthly routine maintenance

At least once a month:

- clean the Receiving Unit with a damp cloth and check if it is damaged;
- make sure that the data plate of the Receiving Unit is undamaged and legible.

14.2.3 Quarterly routine maintenance

At least every three months:

- check that the commands sent and movements carried out by the Machine correspond;
- check that when no movement command is sent the contact of the SAFETY relay is open. After carrying out the maintenance the work must be recorded (date, signature, comments) as evidence that the control was duly carried out. Keep the record together with the other installation documents, since it is an important maintenance intervention concerning safety.

14.3 Special maintenance

By special maintenance is meant the operation and the entirety of repair operations that have to be carried out following breakages, faults or malfunctions of the Radio Remote Control.

Special maintenance brings the Radio Remote Control back to its original conditions of use and operation.



Special maintenance should only be carried out by a qualified Elca person.

The qualified Elca person is a specialised technician who has the specific skills and competences with regard to the Radio Remote Control.

No specialised technician can carry out special maintenance operations on the Radio Remote Control if he does not belong to the Elca assistance network or who is not expressly authorised by Elca.

For the special maintenance operations only original Elca parts and materials should be used.

The instructions and maintenance Manual should be available for the specialised technician entrusted with the special maintenance operations.

When requesting assistance and/or spare parts from Elca, you must provide the serial number of the Radio Remote Control, the date of purchase, and the problem encountered.

To enable the request to be met it is also helpful to know the address of the place where the Radio Remote Control is used, the name and telephone number of the person to contact, as well as the company supplying the Radio Remote Control.

15 Guide to solving problems

If the Radio Remote Control is not working correctly, carry out the following preliminary controls:

- move all the Transmitting Units in the work area away from the Elca Transmitting Unit used, in order to avoid possible radio disturbance and interference;
- move the Elca Transmitting Unit closer to the corresponding Elca Receiving Unit, in order to avoid possible radio disturbance and interference, positioning it always in a safe place with a complete view of the Machine, the work area and the load, if present;
- check to see if the problem is with the Radio Remote Control or the Machine: to this end, it is necessary to do a control test of the Machine using a different control station to the Radio Remote Control, if present. If the problem persists after this test, you need to work on the Machine following the Manufacturer's instructions. Otherwise the problem is with the Elca Radio Remote Control, so further controls will be needed.

15.1 Solutions in the event of malfunctions

The table below indicates the malfunctions that can be encountered when the LED in the Receiving Unit come on and the relative remedies. If the problem persists after implementing the solution indicated, contact the assistance service of the Machine Manufacturer.

SIGNAL	POSSIBLE CAUSE	SUGGESTED REMEDY
No LED comes on.	The Receiving Unit is not powered.	Supply power to the Receiving Unit.
The POWER LED is off.	The Receiving Unit is not powered.	Check for voltage on the power supply terminals. Check that the power cable is connected correctly.
The STATUS LED is off.	The Radio Remote Control is subject to radio disturbance.	Ensure there are no other similar systems or sources of interference such as radio relay systems or transmitters. Switch off the Transmitting Unit and then switch it back on.
	There is no radio link.	Check that the Transmitting Unit is active and correctly connected. Make sure that the operating distance is within the work range and that the Radio Remote Control, has been installed correctly.
The STATUS LED flashes quickly.	The Receiving Unit is awaiting the START from the Transmitting Unit.	Activate the Transmitting Unit and press the START button.
One or more commands do not activate the corresponding movement.	A fuse is damaged.	Check the condition of the fuses inside the Receiving Unit.
	The command was not transmitted.	Check that the Receiving Unit indicator light corresponding to the command activated on the Transmitting Unit comes on.
	The wiring is incorrect.	Check the wiring in the Receiving Unit.

16 Decommissioning and disposal

16.1 Decommissioning

After its decommissioning the Radio Remote Control should be transported and kept in accordance to what is in paragraph 8.5 .

16.2 Disposal

If disposing of all the parts of the Transmitting Unit and its charging system, they all should be treated as separated waste. Disposal should comply with the legal provisions and regulations in force in the country of use.

16.2.1 Waste disposal in the European Union: Directive 2012/19/ EU

In the European Union, all electrical and electronic equipment (EEE) such as radio remote controls must be correctly managed to reduce their environmental impact and protect human health. Therefore, different collection and recycling systems are set out for such equipment.

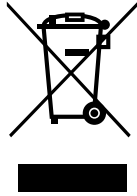

The symbol consisting of a crossed-out wheeled bin indicates that such EEE must be disposed of in conformity with Directive 2012/19/EU.

The symbol with a crossed-out bin provided on the radio remote control indicates that this product must be separately collected from other waste at the end of its life cycle. Separate collection of end-of-life radio remote controls is set up and managed by the manufacturer.

Users who want to dispose of radio remote controls need to contact their manufacturer to receive directions about the separate collection system chosen for end-of-life products.

As an alternative, it is possible to bring any equipment with no dimension more than 25 cm to retail shops with sales areas relating to EEE of at least 400 m², free of charge and with no obligation to buy any new equivalent equipment.

Proper separate collection of end-of-life Radio remote controls and their subsequent recycling, treatment and environmentally sound disposal contributes to preventing possible negative impacts on the environment and on human health, and fosters the reuse and/or recycling of materials radio remote controls are made of.